

The **Compactor Guy** Inc.

Is Pleased To Provide The Following
Stock Room Cardboard Baler Proposal
FOR
Companies Located North America
2008



TCG-M42BC Stock Room Cardboard Baler



2008

Website Visitors

North American Market
USA & Canada

Dear Sir or Madam,

In an effort to provide to our prospective Customers information in the timeliest fashion, we respectfully submit for your consideration the following Cardboard Baling Solution. This unit will produce a tight bale of approximately 175 lbs of Recycled Cardboard. Delivery time is within 2 weeks from date of order as we generally have one or more in stock. This unit is perfectly suited for cardboard recycling and is one of the best units on the market both for its ease of operation and capital outlay requirements. There are additional balers that will produce a 260lb available. Please call us for detailed pricing.

The Compactor Guy Inc. is the Compactor Equipment leader in Canada, servicing customers with compactor and baler needs. Throughout the country we provide rentals, leasing and purchasing programs to such customers as Oshawa Foods, CHIP REIT Hotels, Cineplex Odeon, A & P Services, McDonalds Restaurants, as well as many Shopping Malls, Hospitals, Universities, Warehouses, and independent businesses in the market place.

With any offering in this quote, The Compactor Guy Inc. will provide everything necessary for a complete installation. The pricing in this proposal does not cover any additional costs should you require a Pre-Start-Up Review. Freight will be invoiced separately depending on your site location.

Should you have any questions or concerns please feel free to contact me. I look forward to continuing and enhancing our business relationship into the future.

Regards,

THE COMPACTOR GUY INC.

A handwritten signature in blue ink, appearing to read 'S.A. Bock', written over a horizontal line.

C.A. (Sandy) Bock
President

Overview

The TCG-M42BC Produces bales 42" wide by 22" front to back by a variable 30" High.
Average completed bale weight ranges from 150lbs to 175lbs.

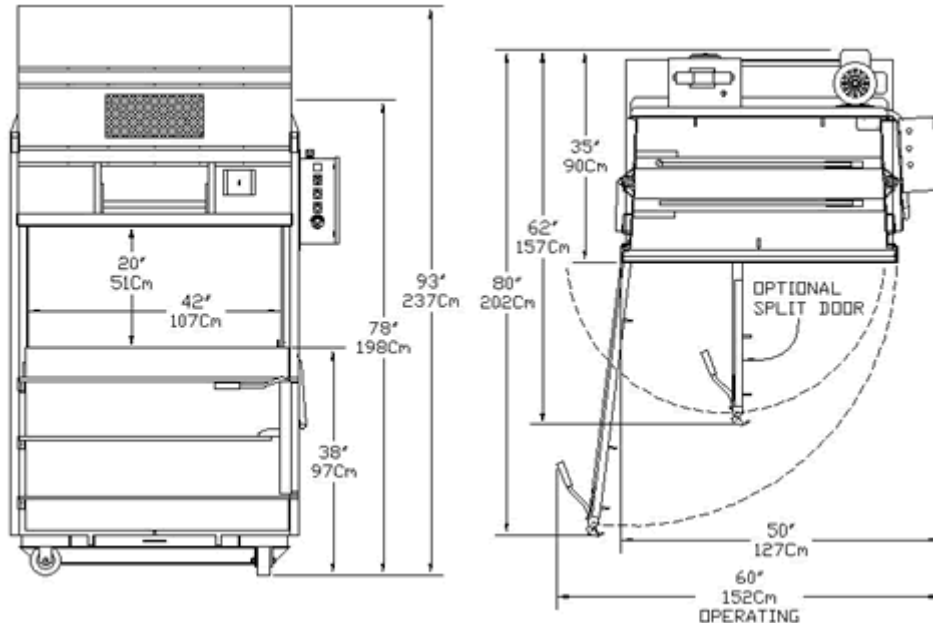

The TCG-M42BC's benefits

- **Entire** Machine UL® Listed
- **Fits** into tight spaces and low ceilings other balers cannot
- **Reduces** waste disposal costs
- **Improves** your business appearance and increases workplace safety
- **Saves** labor and time making your operation more profitable

When you need a common sense answer to your waste problems, look no further than the TCG- M42BC baler from The Compactor Guy, the leader in baler innovation. We have created a winning combination of strength and power all put together in a baler that can fit in your tight space. Loaded with features, and built to provide years of durable service in the harshest of environments, the TCG-M42BC increases your productivity and your bottom line. The TCG-M42BC baler, another great idea from The Compactor Guy Inc.

Features and Specs:

Product Number: TCG-M42BC

Product Name: Vertical Baler

Description: A button controlled down stroke baler, used in baling recyclable materials such as: Corrugated Cardboard, PET Plastic, Aluminum Cans, Shrink Wrap. The TCG-M42BC fits into tight spaces and low ceilings other balers cannot.

The TCG-M42BC is ideal for:

Convenience Stores, Office Developments, Motels/Hotels, Hospitals/Nursing Homes, Restaurants, Department Stores and many other Industrial/Commercial Applications.

TCG-M42BC Specifications		TCG-M42BC Dimensions	
Bale Size	22" x 42" x up to 30" (560mm x 1067mm x up to 762mm)	Loading Door Opening	20" x 42" (508mm x 1067mm)
Bale Weight - Corrugated	Up to 175 pounds (80 kg)	Unloading Door Height	38" (965mm)
Ram Pressure	@ 2000 25,133 pounds (11,400 kg)	Overall Height	93" (2362mm)
Cycle Time	12 seconds	Overall Depth	35" (890mm)
Cylinder	4" (102mm) Bore, 1.5" (38mm) Rod, 10" (254mm) Stroke	Overall Width	50" (1270mm)
Motor	2 HP, 1725 RPM, TEFC	Depth with Door Open	80" (2032mm)
Pump	Two Stage	Width with Door Open	60" (1524mm)
Electrical Power	115/230 Volt, 1 Phase, 60Hz,	Shipping Height	78" (1981mm)
Bale Ejection	Manual Lever System	Shipping Weight	1,475 Pounds (670kg)
Bale Tying	Wire or Twine	Required Operating Area	33.3 Square Feet (3.1 Square Meters)

Method of Acquiring Equipment

TCG-M42 Cardboard Baler

Features:

- Baling Force of 25,133 Lbs
- Interlocking Feed Door and Bale Removal Door.
- Feed Height of 38"
- Very Quick Cycle Time of 12 Seconds
- Cardboard Bale Weighs of 175 lbs Average
- Bale size: 42" x 22" x 30" Std.



Unit to Include:

- 2 HP Motor
- 20" High x 42" Wide Feed Aperture
- Interior Material Retainer Teeth
- Starter Kit Baling Wire or Twine, Customers Choice.
- (Optional Heavy Duty Castors Add \$225.00)
- 115 power Std. Special Twist Plug, Simple Electrical installation.
- Delivery & Installation is included in Southern Ontario
- (Outside Southern Ontario, Additional Charges Apply)

Customer is required to provide special three prong twist outlet to within 6' of the unit.

Purchase:

\$ 8,995.00 plus taxes.

Warranty – One year parts and labor,

A 25% deposit is required at time of ordering and balance due on delivery.

Lease To Own:

***5 Year (60 Month).....\$210.48 per month plus tax**

Buyout option 61st month of \$899.50

Warranty – One year parts and labor

**Errors and omissions accepted*

**Subject to Credit Approval*



Why Use a Baler?

The market for Cardboard & Plastic as with the recycled market in general, varies over time. This means that prices also vary, as the desirability of cardboard & plastic changes. Corrugated cardboard & plastic film or bottles can be accepted from recyclers in different forms. Some companies accept the product in a Gaylord, Front End Container, and Roll-Off Container or on a pallet loose or baled.

Baled material is often more desirable to recyclers, The other benefits of baling the material are that there is a reduced fire risk, less storage is required, less truck traffic on your site, reduction of haulage costs as with open or non baled material and transportation to the recycler is less expensive. In general it definitely adds overall value to the product.

The Compactor Guy Inc. will at your request provide a number of companies that you may use to receive and recycle your baled material. Please contact us for more information.

BENEFITS OF RECYCLING & BALING:

The benefits of recycling Cardboard & Plastic are similar to those of recycling other as the raw materials and the process used in its manufacture are similar, i.e.:

1. Prevents the need for virgin materials. By not felling trees, wildlife habitats are protected, preventing the loss of wildlife.
2. Less cardboard sent for final disposal will mean a reduction in the problems associated with the disposal process.
3. Less energy is used when producing recycled cardboard compared to the use of virgin materials.
4. Recycling cardboard produces fewer emissions to air and water, than production of cardboard from virgin materials.
5. Baling Material is the most efficient method of handling recyclable material. The end user or mill accepts recycled material in bales and by baling on your site you remove a step in the handling process
6. Baling Material is the most efficient method of transporting and storage of recyclable material
7. Baled Material traditionally generates the most income when selling the baled material to the recyclers.

Every MT (Metric Ton) of cardboard recycled saves:

17 trees;

7000 gallons of water;

20 cubic yards of landfill; and 4,100 kw/hours of electricity

The **Compactor Guy** Inc.

The Best Service Guaranteed

24 Hour, 7 Days a Week. Service Line
905-334-0446

The Best Service Guaranteed.

As North America's leading company for compaction equipment, you can count on The Compactor Guy. We deliver the level of service you expect and deserve; Plus, we back it up with the first real service guarantee in the compaction business. Over the past few years we have streamlined our service procedures and added new technologies "Buy without Worry" is the result of these innovations. As a result, we deliver one-on-one local customer attention and service and 100% customer satisfaction Guaranteed.

Our Service Guarantee Really Works For You.

**Service right from the start. Guaranteed.*

We guarantee you'll get the right equipment on time and in the right place.

**Within 6 hours on site visit*

Normally we are on site within 6 hours of your call during business hours.

**Individualized Service. Guaranteed.*

We recognize that every business is different. If there's something else that is important to you, let us know and we will work with you to **INCLUDE SPECIALIZED SERVICES IN YOUR SERVICE GUARANTEE.**

Certain Conditions apply, Call for details.