

The **Compactor Guy** Inc.

Is Pleased To Provide The Following

**Indoor / Outdoor / Drive thru Lobby Pack
TCG-DA1100 Compactor Proposal**

FOR

Website Visitors

2008 / 2009



Our Newest Design is NOW Available

**Two Color Choices
Cobalt Grey & Desert Tan**



Pricing For the Year 2008 / 2009

Welcome Online Visitor:

We would like to introduce the Lobby Pack TCG – DA1100 public use compaction unit. This unit is an easy to use compactor and has many user-friendly features. The cubes that it compacts are less weight and easier to handle than other indoor compacting units currently on the market. It even costs less. The unit operates with a standard wall outlet and is ready to plug in and operate. The lobby packs require no special wiring or a dedicated line. Two units can be plugged into one outlet as the unit does not require high amperage.

The Compactor Guy Inc. is the Compactor Equipment leader in North America, servicing customers with compactor and baler needs. Throughout the country we provide rentals, leasing and purchasing programs to such customers as B.Braun Medical, Apotex Inc. Hospital for Sick Children, Oshawa Foods, A & P Services Canada, CHIP REIT Hotels, Westin Hotels, Cineplex Odeon, McDonalds Restaurants, as well as many independent businesses in the market place.

With any offering in this quote, The Compactor Guy Inc. will provide everything necessary for a complete installation in compliance with WSIB regulations.

Should you have any questions or concerns please feel free to contact me. I look forward to continuing and enhancing our business relationship into the future.

Regards,

THE COMPACTOR GUY INC.

C.A. (Sandy) Bock
President

Advantages, Benefits & Savings, Lobby Pack TCG-1000 Cost Savings & Revenue Enhancements

- ◆ Lobby-Packs can reduce labor for trash related tasks by up to 75% or more
- ◆ Allows Housekeeping to schedule trash detail (usually just one or two trips to the compactor or waste bin per day)
- ◆ Frees up dining area space to allow for more dine-in guests (1 Lobby-Pack can replace the trash volume requirements of many traditional trash bins while also emptying each unit much less.
- ◆ Hand Pick Haulage costs are greatly reduced as many less trash bags and less space required to store trash prior to pick up.

Customer Stated Benefits

- ◆ Eliminates unsightly, overflowing trash receptacle.
- ◆ Positive interaction between Patrons and Lobby Pack Unit increasing Patrons use.
- ◆ Potential for Customer Beneficial promotional messages.
- ◆ Patrons no longer have to experience the unpleasant smells & unsightliness of employees constantly emptying the trash bins.
- ◆ The waste deposit door automatically opens so patrons no longer have to touch an unsanitary waste deposit door with their hands

Safety, Sanitation & Security

- ◆ Eliminates bags of trash accumulating in the large plastic carts, waiting to be taken to the disposal area. This reduces fire hazards and unsanitary conditions.
- ◆ Unit can be adjusted to compact from 20 to 50 lbs thus eliminated any heavy lifting of overweight cubes of trash.
- ◆ Receiving cube has a telescoping handle and wheels built right into it. Simply extend the handle and easily roll it to the trash bin.

Method of Acquiring Equipment

Lobby Pack Model TCG - DA1100 Indoor / Outdoor Drive thru Waste Compactor

Pricing is Per Unit.

Features:

- Automatic Door Opening Sensor (Adjustable)
- Optional Message System, (7 Pre-Programmed, Rotating)
- Automatic Compaction
- Disposable Compaction Plate Cover (easy cleanup)
- Easy Clean and Scratch Resistant Finishes
- Cycle time of 8 seconds.

Each Unit to Include:

- Unit Provided in Choice of 2 Finishes
- Liquid Retention Base Cube Telescopic Handle
- Cube base on wheels, no trash transfer
- Cube Sleeve easily removable
- ** Installation and training is available

Electrical to be supplied by Customer. (115V-10AMP)

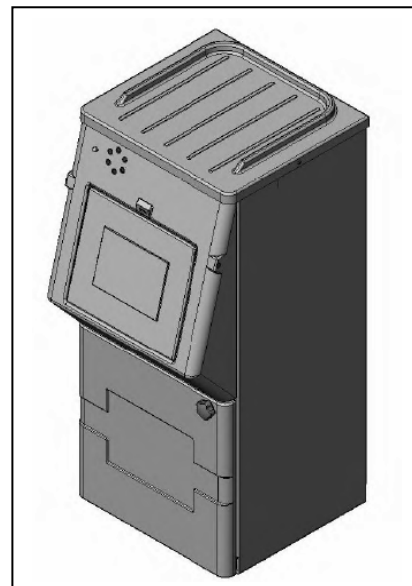

Purchase:

\$ 5495.00 plus tax.

* Warranty – One year parts and labor.

* A 25% deposit is required at time of purchase and balance due on delivery.

Rental: (60 Month)

5 Year (60 Month).....\$125.00 per month plus tax

* Warranty – One year parts and labor.

Lease To Own also available, please call for details.

Volume Discounts Are Available on 10 + Units. (10%)

Additional Operating Costs:

Cube liners: 2mil thick, clear or black roll of one hundred \$75.00 + taxes and delivery.

Now Available in 100% Earth Friendly Degradable format.

Compaction Plate Bonnet, Disposable Easy Clean Up Covers, \$4.00 Each. (Washable)

** Freight to site is extra. Onsite training is available in certain areas, please call for details.

**Errors and omissions accepted*

**Subject to Credit Approval*

3.1 Emptying the Unit



To empty the TCG- DA1000, open the main door.
Using the expandable handle on the cart, pull it from the unit.
Pull the sides of the bag up and secure with a twist tie (not provided) or by tying a knot in the bag.

If so desired, use the cart to transport the bagged waste to the dumpster. Remove the sleeve and dispose of the waste. Replace the sleeve, making sure the sleeve is positioned where it says FRONT.

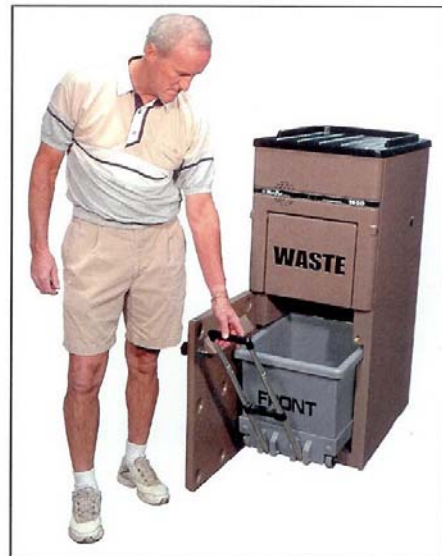
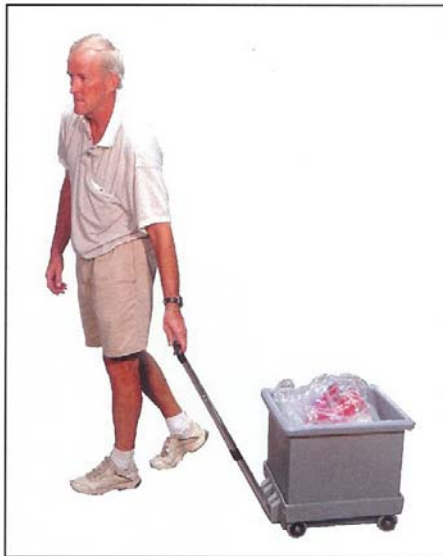

Simple, Easy, Neat & Clean!!



Compaction Plate is Easily Accessed for Cleaning

Compaction Plate Bonnet (Cover) Insures a Clean Compaction Pack Head

Our Newest Model for Indoor and Outdoor Use is now available

- Improved design.
- Up to a 10 to 1 compaction ratio.
- Built to last and easy to clean.
- True compaction NOT a tamper plate.
- Finance or purchase.

OPTIONS:

- Domed or tray lid.
- Indoor or outdoor.
- Voice or no voice.
- Front or back cart removal.
- Custom graphics.

- Eliminates unsightly waste overflows during peak dining times.
- Improves employee efficiency via fewer trash removals.
- Saves money via:
 - Reduced contract hauling.
 - Reduced theft.
 - Labor reduction.
- Improves safety with fewer trips to the dumpster.

- Promotes sanitary and convenient use via "No Touch" door opening sensor.



SPECIFICATIONS:

Compactor: 51" H x 22.25" W x 21.25" D
Removal Door: 22.5" H x 22.5" W
Deposit Door: 13.5" H x 16" W
Bag Size: 16" W x 16" D x 42" T
Weight: 200 Pounds
Compacted Cube Weight: Up to 50 pounds
Electrical: 110/220 volts | 60 hertz | 10 amps
Compaction cycle: 7 seconds



The Best Service Guaranteed

**24 Hour, 7 Days a Week. Service Line
905-334-0446**

The Best Service Guaranteed.

As North America's leading company for compaction equipment, you can count on The Compactor Guy. We deliver the level of service you expect and deserve; Plus, we back it up with the first real service guarantee in the compaction business. Over the past few years we have streamlined our service procedures and added new technologies "Rent without Worry" is the result of these innovations. As a result, we deliver one-on-one local customer attention and service and 100% customer satisfaction Guaranteed.

Our Service Guarantee Really Works For You.

***Service right from the start. Guaranteed.**

We guarantee you'll get the right equipment on time and in the right place.

***Within 6 hours on site visit**

Normally we are on site within 6 hours of your call during business hours.

***Individualized Service. Guaranteed.**

We recognize that every business is different. If there's something else that is important to you, let us know and we will work with you to ***INCLUDE SPECIALIZED SERVICES IN YOUR SERVICE GUARANTEE.***

Certain Conditions apply, Call for details.